

8800 Series Poppet Style Pressure Control Valves

**40 U.S. gpm (151 L/min) nominal;
Standard 3000 psi (210 bar),
HP Option 5000 psi (350 bar)**

Pilot operated valves provide fast response to regulate pressure. The rugged design is ideal for systems with extreme changes in pressure.

SPECIFICATIONS

Mounting

8800 Series, Line Connected;
P8800 Series, Subplate Mounted
(Available in Size 06 only)

Rated Flow

Size 03:

Nominal, U.S. 15 gpm (57 L/min);
Maximum, U.S. 25 gpm (95 L/min)

Size 06:

Nominal, 40 U.S. gpm (151 L/min);
Maximum, 60 U.S. gpm (227 L/min)

Rated Pressure

Standard:

3000 psi (210 bar)

HP Option:

5000 psi (350 bar)

Pressure Adjustment

Standard Pressure Range:

100 to 3000 psi (7 to 210 bar)

HP Option

100 to 5000 psi (7 to 350 bar)

LP Option:

50 to 1000 psi (4 to 70 bar)

Pressure is manually set by turning the maximum pressure adjustment (knurled knob or optional handwheel). Turning clockwise increases pressure. The setting is held by a locknut.

ELECTRIC VENT OPTION

Electrically operated pressure controls are available (normally-open, EVO; or normally-closed, EVC). Pressure is automatically controlled by an integrally mounted D03 valve.

With this option, relief valves can control two pressure levels in a circuit. When the solenoid valve is open, system pressure drops to its lowest level. When the solenoid valve is closed, pressure rises to the control knob setting on the relief valve.



*Electric Vent Option
(Shown: Line Connected)*

*8800 Series
Subplate Mounted*

*8800 Series
Line Connected*

Unloading valves can provide automatic control, diverting pump output to tank during idle portions of the machine cycle.

APPLICATION NOTES

Mounting

Orientation:

Unrestricted for all models.

Subplate Models: Port o-rings are included. Bolts must be ordered separately, .625-11 U.N.C. Threaded x 3.50 inches (88,9 mm). Recommended torque is 55 lb·ft (75 N·m).

See page 3 for "Subplates and Mounting Bolt Kits".

Standard Seals

Fluorocarbon (Viton® or Fluorel®)

Fluid Recommendations

Viscosity:

50 to 1500 SUS (7 to 325 cSt)

Temperature Range:

-20° to +200° F (-29° to +93° C.)

Filtration

Use filtration to provide fluid which meets ISO cleanliness level 19/17/14 (ISO Code 4406) or cleaner.

Pressure Surges

Consistent with standard practice, the system should be protected from pressure surges.

Regulation of internally drained valves may be affected by surges in a common tank line serving multiple valves. A separate line is recommended.

PRESSURE DROP (ΔP)^①

Size	Flow		Vented ΔP	
	U.S. gpm	L/min	psi	bar
03	9	34	35	2,4
	25	95	165	11,4
06	27	102	20	1,4
	60	227	115	7,9

^① Pressure drop is comparable for all pressure ranges.

Valve Functions and Operation

RELIEF VALVES

Relief valves are normally closed controls that regulate pressure to a desired preset maximum.

Their most common use is to protect against excessive pressure. The valve is adjusted so it opens at a pressure slightly higher than the load requirement. When reached, the valve diverts excess pump output flow to tank. See *Figure 1*.

Pressure can be controlled by a remote pressure source, such as a Dynex 8820 Series panel mounted valve.

Relief valves also provide an unloading function, venting pump output flow during idle portions of a machine cycle. Venting can be controlled by a two-position directional control valve (a Dynex D03 valve, for example) in the circuit.

UNLOADING VALVES

Unloading valves are normally closed controls that divert pump output flow directly to tank in response to an external pressure (pilot) signal.

These valves can be used in an accumulator unloading circuit, which provides both relief protection and unloading to divert pump output when the desired accumulator pressure is reached. See *Figure 2*.

The valve closes when the accumulator is discharged to about 85% of the pre-set pressure. This differential unloading characteristic provides faster accumulator recharge.

INTEGRAL VENT VALVE

Pressure controls with optional electric vent can automatically divert pump output flow to tank during idle portions of a machine cycle. Pressure is controlled by an integrally mounted Dynex D03 valve. See *Figure 3*.

This vent option is available in normally-open (EVO) or normally-closed (EVC) configurations.

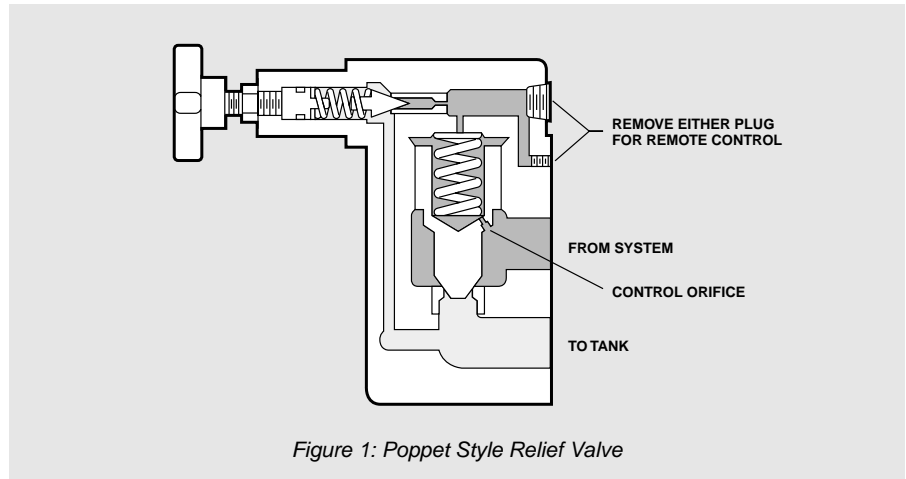

Figure 1: Poppet Style Relief Valve

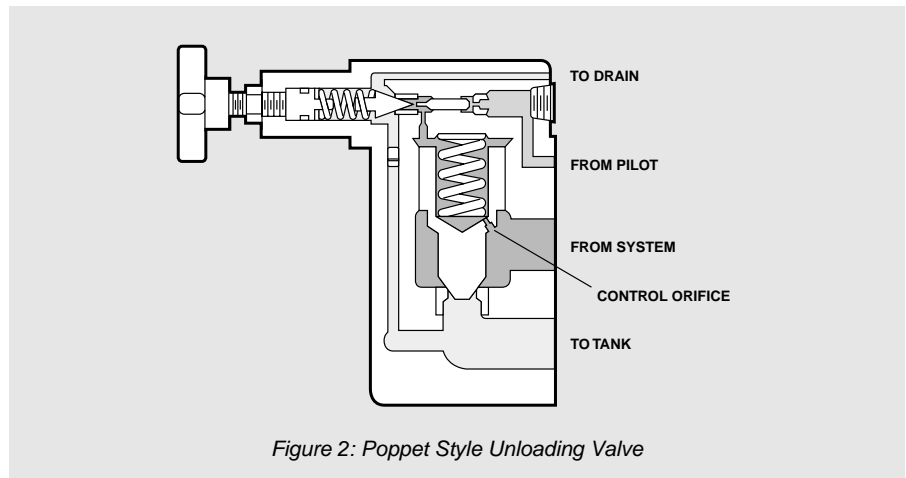

Figure 2: Poppet Style Unloading Valve

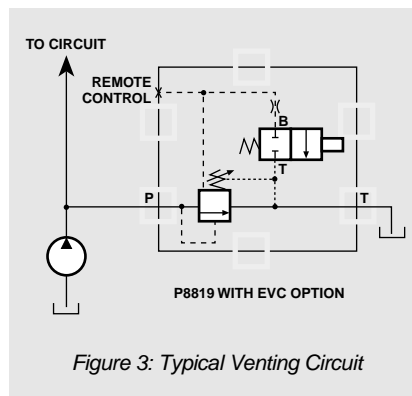

Figure 3: Typical Venting Circuit

Installation and Dimensions

Refer to the table for variable dimensions for line connected models. Note that for installation ease, the pilot head can be rotated 90° counter-clockwise, if desired.

Dimensions for “Electric Vent” option are shown printed in gray.

Weight (Mass)

Size 03:

17 lb (7,7 kg)

Size 06:

Subplate Mounted, 16 lb (7,3 kg);

Line Connected, 20 lb (9,1 kg)

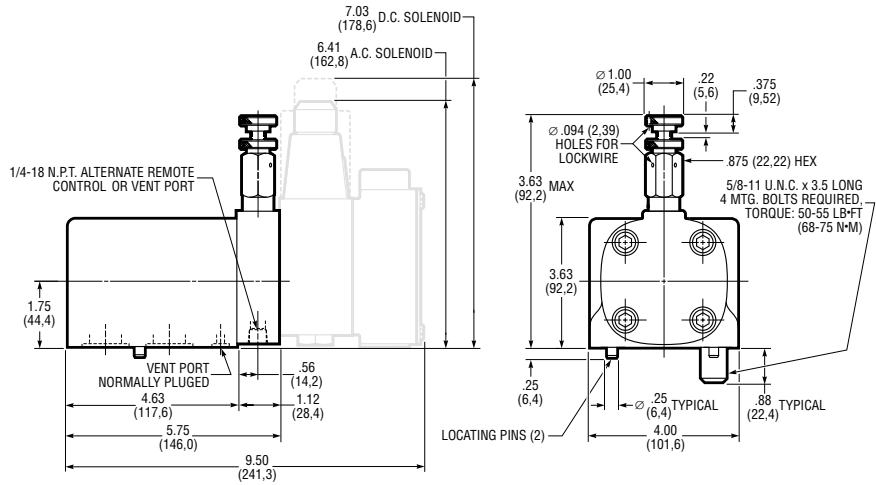

P8800 Series, Subplate Mounted (Size 06 Only)

DIMENSIONS – LINE CONNECTED

	Nominal Size	
	03	06
A	2.62 (66,5)	3.31 (84,1)
B	2.50 (63,5)	3.00 (76,2)
C	4.62 (117,3)	5.62 (142,7)
D	8.38 (212,9)	9.38 (238,3)
E	4.12 (104,6)	4.44 (112,8)
F	1.62 (41,1)	1.84 (46,7)
G	1.31 (33,3)	1.66 (42,2)
H	2.62 (66,5)	3.31 (84,1)
J	3.12 (79,2)	4.50 (114,3)

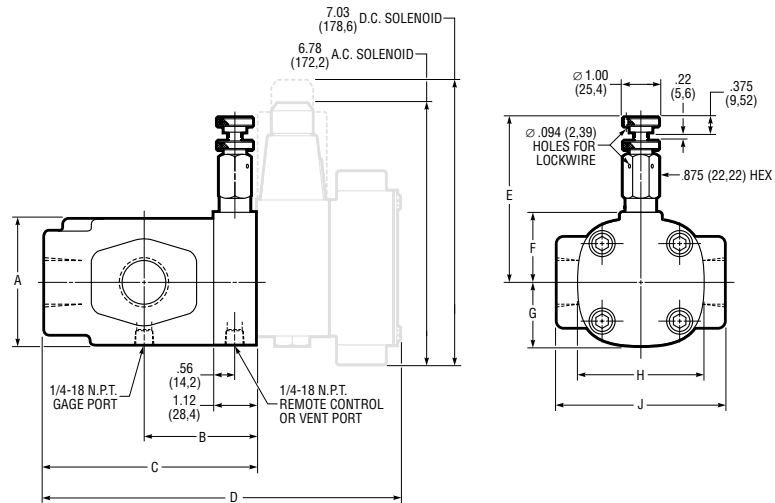

8800 Series, Line Connected

SUBPLATES AND BOLT KITS

P17 (06 Size) subplates are available for mounting under P8800 models.

Valve mounting bolts are supplied when ordering subplates. When ordering valves and subplates together, valves are not mounted on subplates.

The gray area in the drawing indicates the minimum mounting surface required for mounting these valves when a subplate is not used.

Mounting Bolt Kits

Mounting bolts are not included when ordering valve alone. The table includes available mounting bolt kits.

P8800 SERIES (POPPET STYLE)

Item: Part Number	Description
Subplates:	
P17-3/4	Bottom Ports, 3/4-14 N.P.T.F.
P17-1	Side Ports, 1-11-1/2 N.P.T.F.
Bolt Kit: P17-BK	Four .625-11 U.N.C. Threaded x 3.50 inches (88,9 mm)

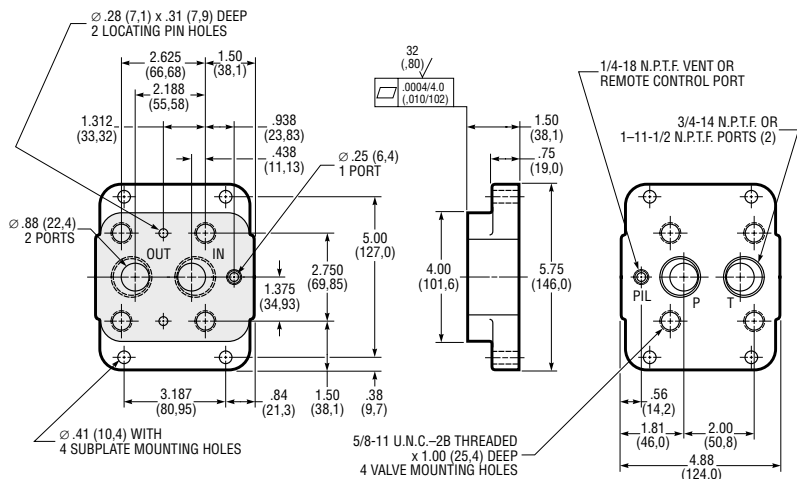

Subplate P17-3/4 or P17-1

P 88 19 — 06 — 3/4 — LP — 115/DF — 1 0

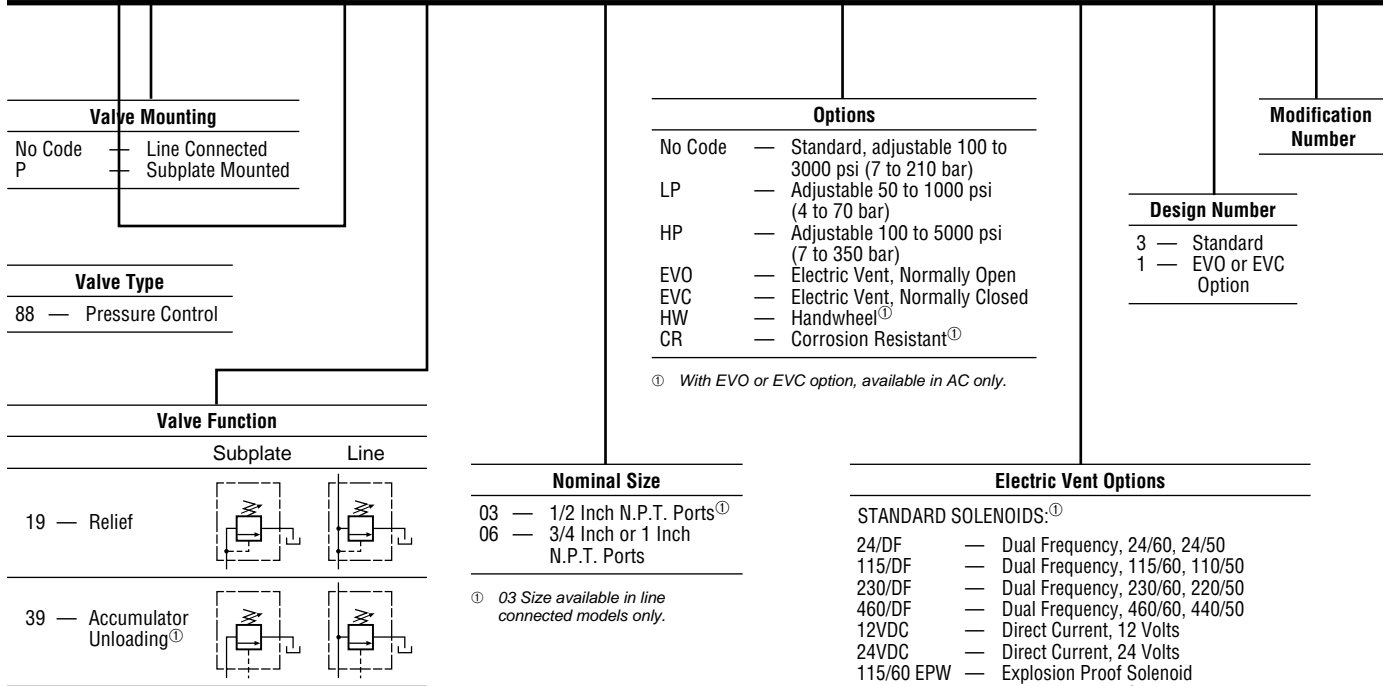

Nominal Size
 03 — 1/2 Inch N.P.T. Ports^①
 06 — 3/4 Inch or 1 Inch N.P.T. Ports

^① 03 Size available in line connected models only.

^① Accumulator unloading function available in 06 Size only.

Electric Vent Options

STANDARD SOLENOIDS:^①
 24/DF — Dual Frequency, 24/60, 24/50
 115/DF — Dual Frequency, 115/60, 110/50
 230/DF — Dual Frequency, 230/60, 220/50
 460/DF — Dual Frequency, 460/60, 440/50
 12VDC — Direct Current, 12 Volts
 24VDC — Direct Current, 24 Volts
 115/60 EPW — Explosion Proof Solenoid
 110/50 EPW — Explosion Proof Solenoid
 220/50 EPW — Explosion Proof Solenoid

PLUG-IN TERMINAL SOLENOIDS:^②
 115/HAC — Dual Frequency, 115/60, 110/50
 230/HAC — Dual Frequency, 230/60, 220/50
 12/HDC — Direct Current, 12 Volts
 24/HDC — Direct Current, 24 Volts

SOLENOID OPTIONS:
 C — CSA and UL Recognized Coils (Etched with Symbol)^③
 M — Hand Actuated Manual Override^④
 T — Terminal Strip^⑤
 CG — Cable Grip, for 3/8 to 7/16 inch (9,5 to 11,1 mm) O.D. machine tool cable^③
 SL — Solenoid Lights (Available 115/DF AC Only)^③
 HPT — High Pressure Tank Port^④
 2300 psi (160 bar) maximum AC models
 3000 psi (210 bar) maximum DC models
 BH3A — 3-pin Connector (NFPA standard T3.539-1980), for single solenoid models, on port "A" end of valve^③
 BH3B — 3-pin Connector, for single solenoid models, on port "B" end of valve^③
 BH5A — 5-pin Connector for single or double solenoid models on port "A" end of valve^③
 BH5B — 5-pin Connector for single or double solenoid models on port "B" end of valve^③

^① For other voltages, consult the Dynex sales department.
^② Fits DIN Connector Standard 43650 (Hirschmann GDM 209).
^③ Available with 115/DF solenoids only. For other voltages, consult the Dynex sales department.
^④ Option not available with "EPW" solenoid models.
^⑤ Options not available with "EPW" nor "Plug-In Terminal" solenoid models.

For more information
 visit our web site:
www.fullyeartrading.com